



900 MHz Digital

**Cordless
Telephone**

User Guide



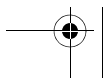
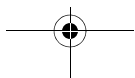
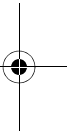
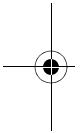
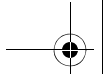

VERTICAL Ranger Cordless Telephone



Issue	Release	Changes
1.0	6-07	Initial Release

© 2007 Vertical Communications, Inc. All rights reserved. Vertical Communications and the Vertical Communications logo and combinations thereof and Ranger are trademarks of Vertical Communications, Inc. All other brand and product names are used for identification only and are the property of their respective holders.

set/2007

TABLE OF CONTENTS

IMPORTANT SAFETY INSTRUCTIONS	iii
WARNINGS.....	v
SAVE THESE INSTRUCTIONS.....	vii
ONE YEAR LIMITED WARRANTY	ix
About Your Ranger Cordless Telephone.....	1
Features of the Ranger Cordless Telephone	2
Handset Controls & Functions	3
Base Unit Controls & Functions	4
Installing Your Ranger Cordless Telephone	5
Selecting the Installation Location.....	5
Connecting the Telephone Cord	5
Connecting Power to the Base and Charger Units	6
Wall Mounting	7
Attaching the Belt Clip to the Handset	11
Installing the Handset Battery Pack	12
Charging the Handset Battery Pack.....	13
Checking the Low Battery Indicator	13
Cleaning Charging Unit Contacts.....	13
Using Your Ranger Cordless Handset.....	14
Ranger Cordless Handset Controls	14
Earpiece Volume.....	15
Handset Ringer Tone and Volume.....	16
Vibrate Mode.....	16
Handset Ringer Mute	16
Using the Handset.....	17
Basic Phone Features.....	18
Answering a Call	18
Establishing a Conference Call	18
Forwarding a Call	19
Making a Page Announcement	19
Placing a Call	19
Placing a Call on Hold.....	19
Retrieving Voice Messages.....	20
Transferring a Call.....	20
Using the Redial Function	20

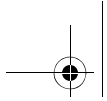

Programming Functions..... 21

- Setting Up a Flexible Button..... 21
- Storing Speed Numbers..... 22
- Dialing a Speed Number 22
- Setting Speed Dial & Last Number Redial Mode 22

Troubleshooting..... 23

Specifications..... 24

Part Numbers 25

IMPORTANT SAFETY INSTRUCTIONS

NOTE -- The *Ranger Cordless Telephone* is only intended for use with the following Vertical systems: XTS-IP, XTSc-IP and STSe systems.

When using your telephone equipment, basic safety precautions should always be followed to reduce the risk of fire, electrical shock, and injury to persons, including the following:

- Read and understand all instructions.
- Follow all warnings and instructions marked on the product.
- Unplug this product from the wall outlet before cleaning. Do not use liquid cleaners or aerosol cleaners. Use a dry cloth for cleaning.
- Do not use this product near water (e.g., near a sink or in a wet area).
- Do not place this product on an unstable cart, stand, or table. The telephone may fall, causing serious damage to the unit.
- To protect the product from overheating, do not block or cover any slots or openings in the base Unit. This product should never be placed near or over a radiator or heat register. This product should not be placed in a built-in installation unless proper ventilation is provided.
- This product should be operated only from the type of power source indicated on the marking label.
- Do not allow anything to rest on the power cord. Do not locate this product where the cord will be damaged by persons walking on it.
- Do not overload wall outlets and extension cords, as this can result in the risk of fire or electrical shock.
- Never push objects of any kind into this product through the Base Unit slots, as they may touch dangerous voltage points or short out parts that could result in a risk of fire or electric shock. Never spill liquid of any kind on the product.
- Do not disassemble this product to reduce the risk of electric shock. Contact qualified service personnel when some service or repair work is required. Opening or removing covers may expose you to dangerous voltages or other risks. Incorrect reassembly can cause electric shock when the appliance is subsequently used.
- Do not use the phone to report a gas leak in the vicinity of the leak.

IMPORTANT SAFETY INSTRUCTIONS

- Unplug this product from the wall outlet and refer servicing to qualified service personnel under the following conditions:
 - When the power supply cord is damaged or frayed.
 - If liquid has been spilled into the product.
 - If the product has been exposed to rain or water.
 - If the product does not operate normally when following the operating instructions. Adjust only those controls that are covered by the operating instructions. Improper adjustment of other controls may result in damage, and will often require extensive work by a qualified technician to restore the product to normal operation.
 - If the product has been dropped, or the cabinet has been damaged.
 - If the product exhibits a distinct change in performance.

WARNINGS

CAUTION

Changes or modifications to this product not expressly approved by Vertical Communications, or operation of this product in any way other than as detailed by this User Guide, could void your authority to operate this product.

Unplug all electrical appliances when you know an electrical storm is approaching. Lightning can pass through your household wiring and damage any device connected to it. This phone is no exception.

NOTE: Do not attempt to unplug any appliance during an electrical storm.

NOTICE

The *Ranger Cordless Telephone* is not waterproof. To reduce the risk of fire, electrical shock, or damage to the unit, **do not** expose this unit to rain or moisture.

WARNINGS

Your new phone is designed to achieve the maximum possible range by transmitting and receiving according to the highest specifications set forth by the FCC and IC. We have rated this phone to operate at a maximum distance with the qualification that the range depends upon the environment in which the telephone is used. Many factors limit range, and it would be impossible to include all the variables in our rating. The Maximum Range rating of this phone is meant to be used as a means of comparison against other range claims.

The FCC and IC have granted the telephone company the right to disconnect service in the event that your phone causes problems on the telephone line. Also, the telephone company may make changes in facilities and services which may affect the operation of your unit. However, your telephone company must give adequate notice in writing prior to such actions to allow you time for making necessary arrangements to continue uninterrupted service.

If you are having trouble with your telephone service, you must first disconnect your phone to determine if it is the cause of your problem. If you determine that it is the cause, you must leave it disconnected until the trouble has been corrected.

Radio interference may occasionally cause buzzing and humming in your cordless Handset, or clicking noises in the Base Unit. This interference is caused by external sources such as a TV, refrigerator, vacuum cleaner, fluorescent lighting, computer equipment, or electrical storm. Your unit is **NOT DEFECTIVE**. If these noises continue and are too distracting, please check around your office to see what appliances may be causing the problem. In addition, we recommend that the Base not be plugged into a circuit that also powers a major appliance because of the potential for interference. Be certain that the antenna on the unit is fully extended when needed.

In the unlikely event that you consistently hear other voices or distracting transmissions on your phone, you may be receiving radio signals from another cordless telephone or other source of interference. If you cannot eliminate this type of interference, you need to change to a different channel.

SAVE THESE INSTRUCTIONS

Finally, it should be noted that some cordless telephones operate at frequencies that may cause interference to nearby TVs and VCRs. To minimize or prevent such interference, the base of the cordless telephone should not be placed near or on top of a TV or VCR. If interference is experienced, moving the cordless telephone farther away from the TV or VCR will often reduce or eliminate the interference.

When using more than one *Ranger Cordless Telephone* or *Ranger SS Cordless Telephone* in a constrained physical area, the phones must operate on different frequencies (channels). If there are multiple phones in an area where the base stations are closely located, there is a chance that there could be interference between the units if two or more units are trying to operate on the same frequency simultaneously. If there is a noticeable degradation of call quality, the user can press the Channel Key to select a channel that provides the clearest communication to restore the quality of the call.

NOTE: Cordless phones are radio devices. Communications between the Handset and Base Unit of your cordless telephone are accomplished by means of radio waves which are broadcast over the open airways. Because of the inherent physical properties of radio waves, your communications can be received by radio receiving devices other than your own cordless telephone unit. Consequently, any communications using your cordless telephone may not be private.

The handsets are programmed to work with a specific base unit. You cannot switch to a new handset or a new base unit without having it reprogrammed by Vertical Communications.

SAVE THESE INSTRUCTIONS

The battery packs contain rechargeable, sealed Nickel-Metal-Hydride batteries. To reduce the risk of fire or injury to persons by the battery, read and follow these instructions:

- Use only the appropriate type and size Battery Pack specified in this Operating Guide.
- Do not dispose of the Battery Pack in a fire. The cell may explode. Check with local codes for possible special disposal instructions.
- Do not open or mutilate the Battery Pack. Released electrolyte is corrosive and may cause damage to the eyes or skin. It may be toxic if swallowed.
- Exercise care in handling the battery in order not to short the battery with conducting materials such as rings, bracelets, and keys. The battery or conductor may overheat and cause burns.
- Do not charge the Rechargeable Nickel-Metal-Hydride battery used in this equipment in any charger other than the one designed to charge this battery as specified in the owner's manual. Using another charger may damage the battery, or cause the battery to explode.
- Charge the Battery Pack provided with or identified for use with this product only in accordance with the instructions and limitations specified in the instruction manual provided for this product.
- Observe proper polarity orientation between the Battery Pack and battery charger.
- Do not short-circuit the battery.

ONE YEAR LIMITED WARRANTY

WARRANTOR: Vertical Communications

ELEMENTS OF WARRANTY: Vertical Communications warrants, for one year, to the original retail owner, this Vertical Product to be free from defects in materials and craftsmanship with only the limitations or exclusions set out below.

WARRANTY DURATION: This warranty to the original user shall terminate and be of no further effect 12 months after the date of original retail sale. The warranty is invalid if the Product is (A) damaged or not maintained as reasonable or necessary, (B) modified, altered, or used as part of any conversion kits, subassemblies, or any configurations not sold by Vertical Communications, (C) improperly installed, (D) serviced or repaired by someone other than an authorized Vertical Communications service center for a defect or malfunction covered by this warranty, (E) used in conjunction with equipment or parts or as part of any system not manufactured by Vertical Communications, or (F) installed or programmed by anyone other than as detailed by the Operating Guide for this product. Vertical's obligation under this warranty is limited to repair or replacement, at Vertical's option, of defective parts.

STATEMENT OF REMEDY: In the event that the product does not conform to this warranty at any time while this warranty is in effect, warrantor will repair the defect and return it to you without charge for parts, service, or any other cost (except shipping and handling) incurred by warrantor or its representatives in connection with the performance of this warranty. **THE LIMITED WARRANTY SET FORTH ABOVE IS THE SOLE AND ENTIRE WARRANTY PERTAINING TO THE PRODUCT AND IS IN LIEU OF AND EXCLUDES ALL OTHER WARRANTIES OF ANY NATURE WHATSOEVER, WHETHER EXPRESS, IMPLIED OR ARISING BY OPERATION OF LAW, INCLUDING, BUT NOT LIMITED TO ANY IMPLIED WARRANTIES OF MERCHANTABILITY OR FITNESS FOR A PARTICULAR PURPOSE. THIS WARRANTY DOES NOT COVER OR PROVIDE FOR THE REIMBURSEMENT OR PAYMENT OF INCIDENTAL OR CONSEQUENTIAL DAMAGES.** Some states do not allow this exclusion or limitation of incidental or consequential damages so the above limitation or exclusion may not apply to you.

LEGAL REMEDIES: This warranty gives you specific legal rights, and you may also have other rights which vary from state to state. This warranty is void outside the United States of America.

PROCEDURE FOR OBTAINING PERFORMANCE OF WARRANTY: If, after following the instructions in this User Operating Guide you are certain that the Product is defective, the authorized installer should contact Vertical's Customer Support Department at (800) 356-7279 for further instructions.

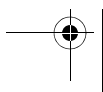
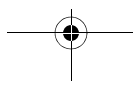
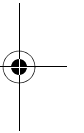
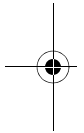
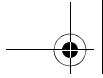

About Your *Ranger Cordless Telephone*

The Vertical *Ranger Cordless Telephone* is designed and engineered to exacting standards for reliability, long life, and outstanding performance. It is designed to work with a Vertical phone system (XTS-IP, XTSc-IP, or STSe).

- To get the most from your *Ranger Cordless Telephone*, read this Operating Guide thoroughly.
- To help familiarize you with the features of your cordless phone, refer to the Handset and Base Unit illustrations.

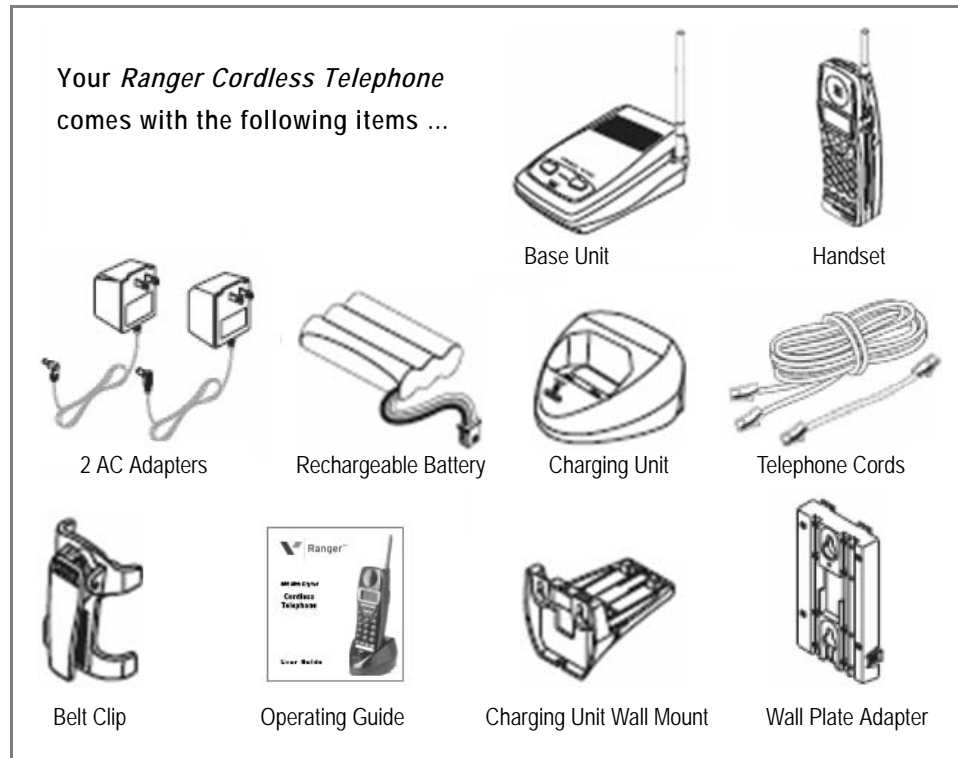

NOTE

- If any of these items are missing or damaged, contact your System Administrator.
- If your *Ranger Cordless Telephone* is not performing to your expectations, try the simple steps listed in the Troubleshooting section of this Guide.
- If you are still unable to resolve the problem, contact your System Administrator.

Features of the *Ranger Cordless Telephone*

Each Ranger Cordless Telephone has the following features:

- 2-line, 16-digit LCD Display
- Easy Installation
- Four Flexible Function Keys: Loop 1, Loop 2, Pickup & Voice Mail
- Handset Volume Control
- Headset Jack (2.5mm)
- Long Range 900MHz Digital
- Low Battery Protection System
- One-button access to: CONFERENCE, HOLD, TRANSFER, & SPEED features
- Out of Range Protection
- Ringer Volume Control
- Separate Charging Stand
- Vibrate/Ringer Alert
- Wall Mountable separate Base Unit
- Wall Mountable separate Charging Unit

Handset Controls & Functions

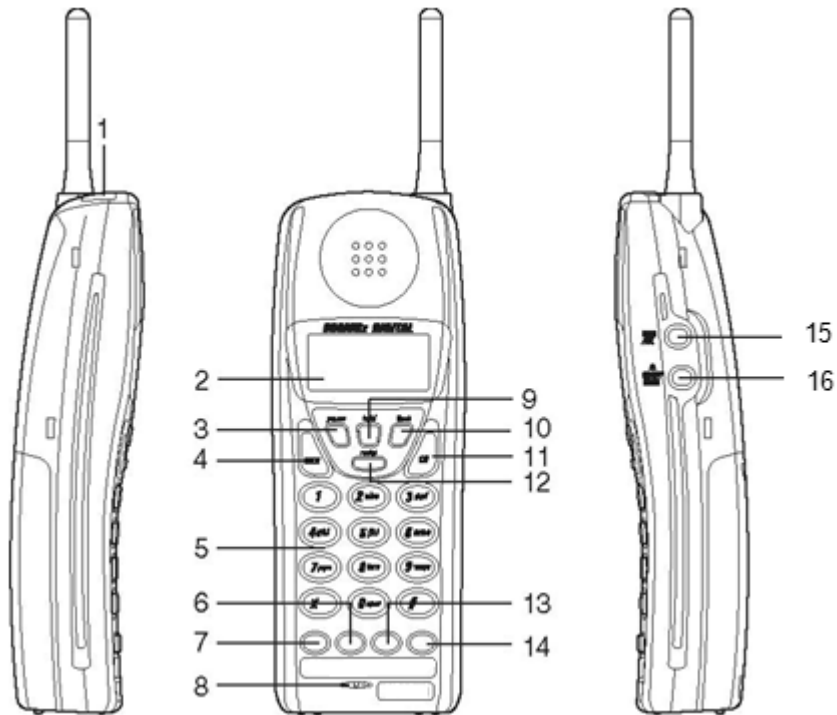

- | | |
|--------------------------------|---|
| 1. Headset Jack | 9. Transfer (xfer) Key |
| 2. Message Display | 10. Conference (conf) Key |
| 3. Hold (hold) Key | 11. Channel (CH) Key |
| 4. Talk (TALK) Key | 12. Speed Key |
| 5. Numeric Keypad | 13. Flex Key (default - Pick Up) |
| 6. Flex Key (default - Loop 2) | 14. Flex Key (default - Voice Mail) |
| 7. Flex Key (default - Loop 1) | 15. Volume (RING/VOL) Key |
| 8. Microphone | 16. Ringer ON/OFF & Mic Mute
(MUTE) Key |

Base Unit Controls & Functions

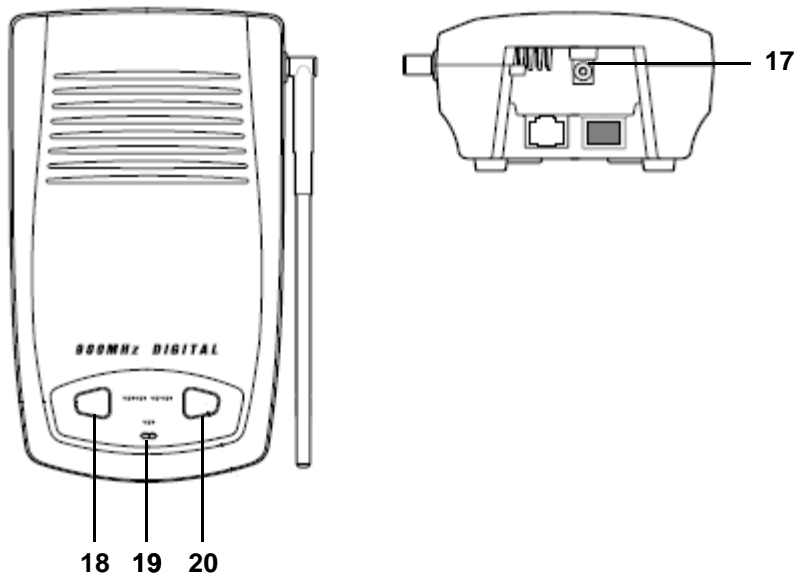

- 17. DC Power Jack
- 18. Handset Locator Key
- 19. Power (On/Off) LED
- 20. Handset Locator Key

Installing Your *Ranger Cordless Telephone*

Selecting the Installation Location

Select a location for the *Ranger Cordless Telephone* to avoid excessive heat or humidity. The Base Unit of your *Ranger Cordless Telephone* can be placed on a desk or tabletop near a standard 120V AC outlet and telephone line jack. The Base Unit can also be mounted on a standard wall plate using the included Wall Mount Adapter. Keep the Base Unit and Handset away from sources of electrical noise (motors, fluorescent lighting, computers).

Connecting the Telephone Cord

Plug the telephone line cord from the Base Unit into one of the following Vertical digital telephone system ports: XTS-IP, XTSc-IP, or STSe.

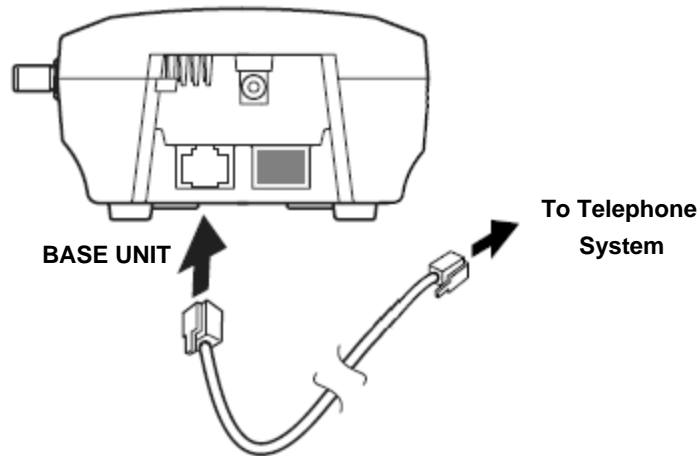

Connecting Power to the Base and Charger Units

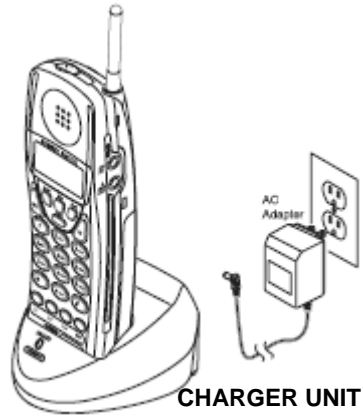

NOTE -- A flashing LED on the charger indicates the handset is not seated properly, the battery is not hooked up, or the phone is not in service.

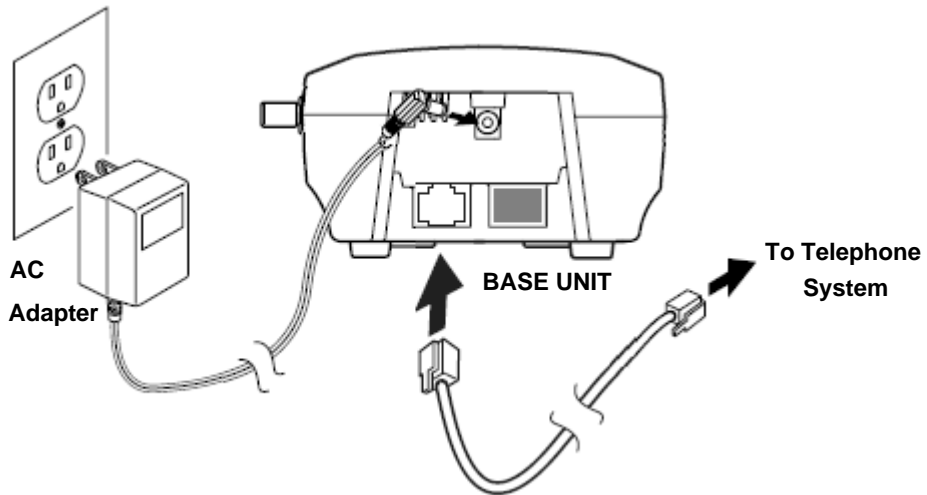

NOTE -- *Do not* route the power cord where it will create a trip hazard, or where it could become worn and create a fire or other electrical hazards.

Wall Mounting

You can mount the *Ranger Cordless Telephone* on a standard wall plate or directly on a wall.

Standard Wall Plate Mounting

Your *Ranger Cordless Telephone* is designed to be mounted on a standard wall plate.

To attach the wall mount stand to the Base Unit:

1. Slide the Wall Mount stand into the notches at the top of the Base Unit, push the Wall Mount stand down and snap it into place.
2. Plug the AC Adapter into the Base Unit as previously described.

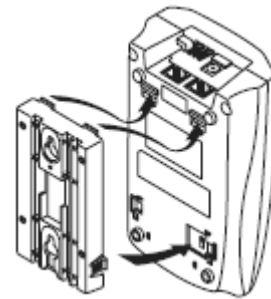

3. Place the AC Adapter cord inside the molded channel of the Wall Mount stand.
4. Plug one end of the short telephone cord into the LINE jack on the Base Unit. Then place the telephone cord inside the molded channel on the bottom of the Wall Mount stand.
5. Plug the other end of the short telephone cord into the modular wall jack.

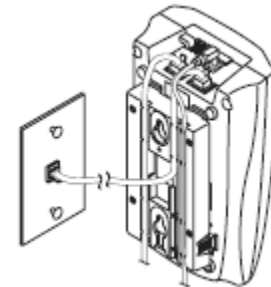

6. Place the Base Unit on the posts of the wall plate and push down until it's firmly seated.
7. Plug the AC Adapter into a standard 120V AC wall outlet.

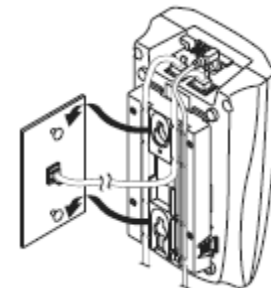

NOTE -- *Do not use an outlet controlled by a wall switch. Turning the wall switch off will also turn the base unit off.*

Direct Wall Mounting

If you do not have a standard wall plate, you can mount your phone directly on a wall. Before mounting your phone, consider the following:

- Select a location away from electrical cables, pipes, or other items behind the mounting location that could be hazardous when placing screws into the wall.
- Make sure wall material is capable of supporting the weight of the Base Unit.
- Use #10 screws with anchoring devices suitable for the wall material where the Base Unit will be placed.

To mount the base unit on a wall:

1. Insert two mounting screws $3 \frac{15}{16}$ inches apart. Allow about $\frac{3}{16}$ of an inch between the wall and screw heads for mounting the phone.
2. Plug and secure the AC Adapter cord by following steps 2 and 3 of the "Standard Wall Plate Mounting".
3. Plug one end of the telephone line cord into the LINE jack on the Base Unit. Then place the telephone cord inside the molded channel on the bottom of the Wall Mount stand.
4. Place the Base Unit on the posts of the wall screws and push down until it's firmly seated.
5. Plug the other end of the short telephone cord into a telephone wall jack.
6. Plug the AC Adapter into a standard 120V AC wall outlet.

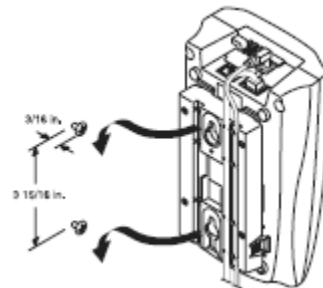
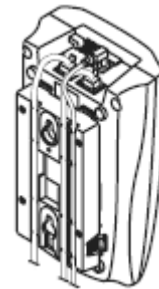
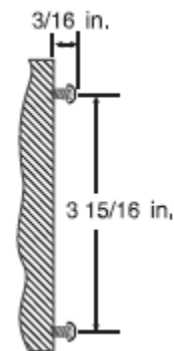

Charging Unit Wall Mounting

The Charging Unit is also designed to be wall mounted. Before mounting your charging unit, consider the following:

- Select a location away from electrical cables, pipes, or other items behind the mounting location that could be hazardous when placing screws into the wall.
- Make sure the wall material is capable of supporting the weight of the Charging Unit.
- Use #10 screws with anchoring devices suitable for the wall material where the Charging Unit will be placed.

To mount the charging unit on a wall:

1. Insert two mounting screws 1-1/5 inches apart. Allow about 3/16 of an inch between the wall and screw heads for mounting the phone.

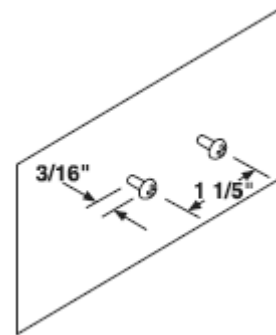

2. Pass the one end through the hole of the wall mount stand and plug it into the Charging Unit. Wrap the AC Adapter cord around the strain relief.

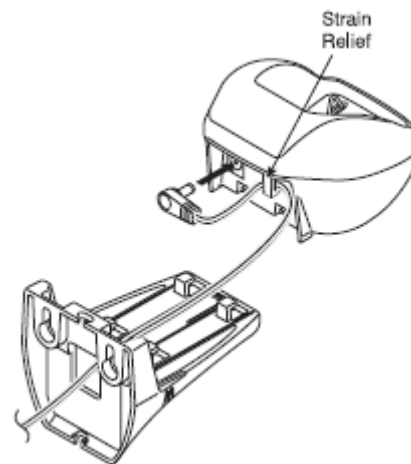

- Slide the wall mount stand into the notches on the bottom of the Charging Unit.

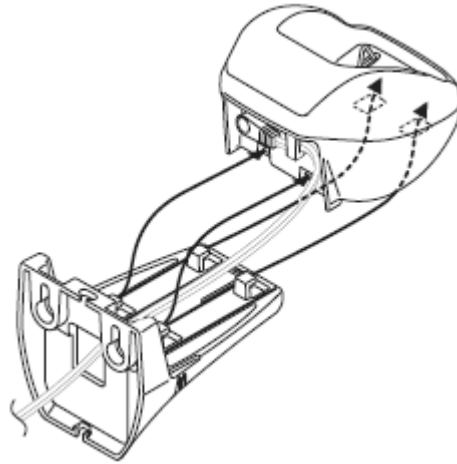

- Place the Charging Unit on the posts of the wall screws and push down until it's firmly seated.

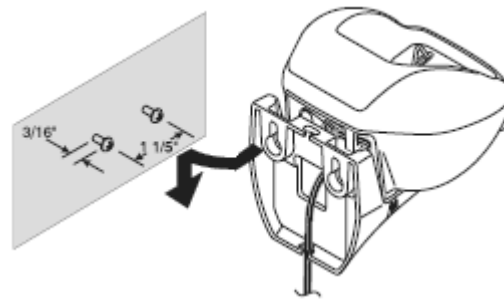

- Plug the AC Adapter into a standard 120V AC wall outlet.

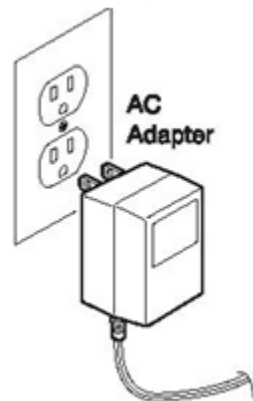

Attaching the Belt Clip to the Handset

You can use the Belt Clip to attach the Handset to your belt or pocket for convenient portability.

To attach the belt clip to the handset:

1. Snap the tab out of the Belt Clip notch on the top of the Handset.
2. Slide the clip into the tab slot. The Belt Clip is designed to fit snugly onto the Handset.
3. Press firmly until the belt clip snaps into place.

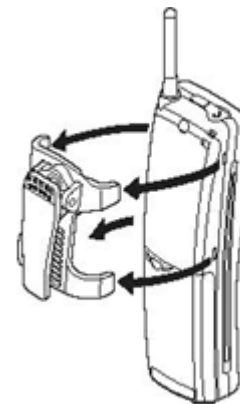
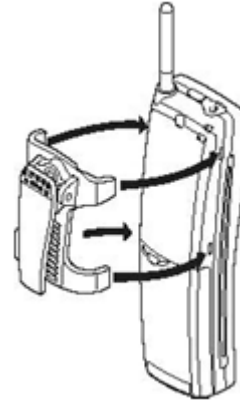

To remove the belt clip from the handset:

Press the retaining clip in (toward the Belt Clip blade) and slide the clip up at the same time. Once the belt clip is removed, reinstall the cover tab.

Installing the Handset Battery Pack

To install the battery pack:

1. Remove the battery cover by pressing the latch and sliding the cover down and off of the Handset.

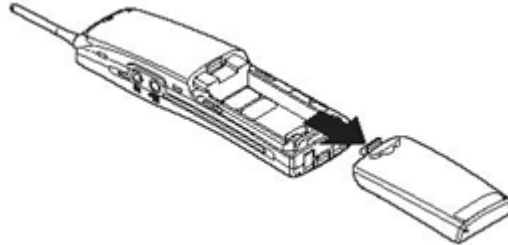

2. Connect the battery pack connector, observing correct polarity to the jack inside the battery compartment, as shown on the right.

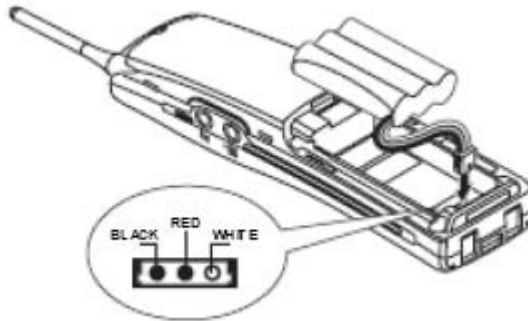

NOTE

- To avoid causing damage to the battery or handset, do not exert any force on this connection.
 - Once you have made a good connection, then insert the battery pack into the battery compartment.
 - Do not pinch the wires.
-

3. Replace the cover and slide the it up until it latches into the Handset.

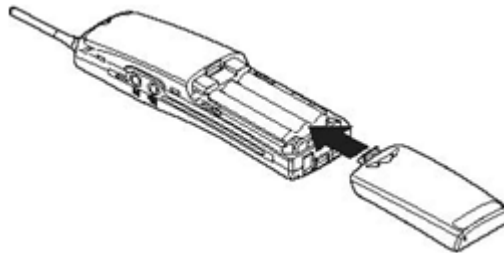

Charging the Handset Battery Pack

To charge the battery pack:

1. Place the Handset into the Charging Unit.
2. Make sure the CHARGE indicator illuminates.
If the CHARGE light doesn't illuminate, check to see that the AC Adapter is plugged in, and that the Handset is making good contact with the Charging Unit charging contacts.

NOTE -- If you are using the *Ranger Cordless Telephone* for the first time, fully charge the rechargeable Ni-MH battery pack for 5 hours without interruption.

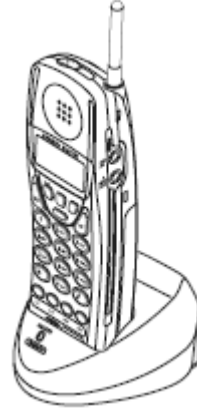

Checking the Low Battery Indicator

When the Battery Pack in the Handset is low and needs to be charged, the LOW message appears on the display. See the table below for what action to take when this occurs.



When on a call ...	When in standby mode ...
<ul style="list-style-type: none"> • The Handset will beep once every 3 seconds. • All keys and functions will be available. 	<ul style="list-style-type: none"> • The Handset will beep every 15 seconds for 3 minutes. • None of the keys will operate and you cannot place or receive a call.
<p><i>Action</i> --> Complete your call as quickly as possible, or replace battery pack within 20 seconds to continue call.</p>	<p><i>Action</i> --> Replace the battery pack before making a call.</p>

Cleaning Charging Unit Contacts

To maintain a good charge, it is important to clean all charging contacts on the Handset, and Charging Unit about once a month.

--> Use a pencil eraser or other contact cleaner.
Do not use any liquids or solvents.

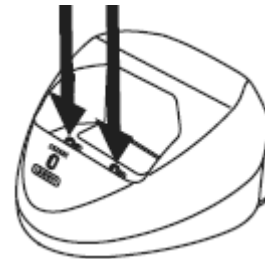

Using Your *Ranger* Cordless Handset

--> *The steps and procedures shown in this section assume you are using the factory default settings preprogrammed on your Ranger Cordless Telephone.*

Before using your *Ranger Cordless Telephone*, be sure to raise the antenna to the vertical position as shown on the right.

NOTE -- Operation of the *Ranger Cordless Telephone* is performed using the Handset out of the Charging Unit.



Ranger Cordless Handset Controls

The **RING/VOL** key is used to:

- Set the volume of the earpiece.
- Adjust the ringer tone and volume of the handset.

The **ON/OFF Mute** key is used to activate or deactivate the mute function of the Handset ringer tone.

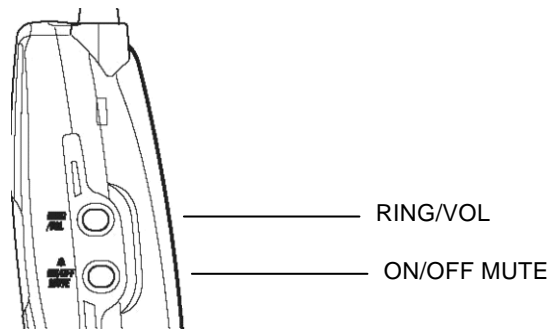

Earpiece Volume

During a call ... press the **RING/VOL** key on the side of the Handset to select the earpiece volume of the handset.

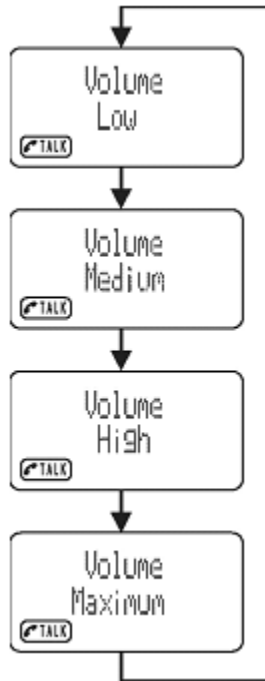

Handset Ringer Tone and Volume

Press the **RING/VOL** key on the side of the Handset to select seven (7) ringer tones and volume combinations.

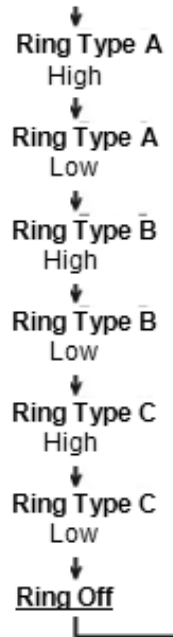

Vibrate Mode

Selecting the “Ring Off” setting shown above, places the *Ranger Cordless Telephone* into Vibrate Mode.

- If you set the Ringer to OFF and the Handset is not on the charger, the Handset will vibrate when there is an incoming call.
- If you set the Ringer to OFF and the Handset is on the charger, the Handset will ring as Ring Type A - Low.

Handset Ringer Mute

You can temporarily mute the handset ringer tone.

- Press and hold the **ON/OFF MUTE** key on the side of the handset for 2 seconds. You will see the Ring OFF icon.
- If you press and hold the **ON/OFF MUTE** key for 2 seconds again, the Ring OFF icon will disappear.



Using the Handset

When you pick up the handset and press **TALK**, the “ACQUIRING LINK” message appears, as shown on the right.



After the connection has been made between the handset and base unit, the **TALK** icon appears on the display. The screen goes into standby mode and the phone is ready to use.



If the handset is at the range limit of the *Ranger Cordless Telephone*, or no power is going to the base unit, you may see the “NO SERVICE” message, as shown on the right.



Take the following action:

During a Call ...	In Standby Mode ...
The sound is muted.	You can not make or answer a call (phone may ring intermittently).
<i>Action --></i> Move back in range within 20 seconds or check power to the base unit.	<i>Action --></i> Move back within range, or check the power to the base unit.

Basic Phone Features

Answering a Call

When you receive a call, the Handset rings and you will see:



Handset in the Charging Unit	Handset out of Charging Unit
Pick up the Handset.	<p>Press TALK, -or- press any key on the numeric keypad, -or- press the Hold, Speed, Conf or Xfer key.</p> <ul style="list-style-type: none"> • Flexible button L1 can be used only when the call is on line 1, flexible button L2 only when the call is on line 2. • When you are on a call and you receive a 2nd incoming call, you will hear 1 short beep and the Loop key will start to flash.
<p>--> When you finish the call, place the Handset back in the Charging Unit. --> Press TALK to hang up the phone.</p>	

Establishing a Conference Call

1. Press **TALK** and dial an intercom station, OR dial the desired outside party.
2. When the called party answers, press the **CONF** key.
3. Add the next conference party by dialing another intercom station, OR dial **[9]** + the second party's outside number.
4. If the next conference party is an outside line and a busy or wrong number is encountered, place one of the conference parties on hold. This drops the busy or wrong number party. Press **CONF** again and repeat Step 4.
5. When the last party answers, press **CONF** twice.

To terminate a Conference, the conference initiator who is actively in the conference must press the **TALK** key to end the call.

Forwarding a Call

1. Press **TALK** and dial feature code [640].
2. Dial the desired Call Forward code: [6] = All Calls [7] = No Answer [8] = Busy [9] = Busy/No Answer [*] = Off-Net
3. Dial the station number where calls are to be forwarded or the desired speed bin. A confirmation tone will sound.
4. Press **TALK**.

Making a Page Announcement

If given the ability to make page announcements:

1. Press **TALK** and dial a three-digit paging code,
-or-
Press the *preprogrammed* PAGING flexible button.
2. Speak in a normal tone of voice to deliver your message.

NOTE -- *When using the cordless handset ... you can send an Internal or External Page but you will be unable to receive a page.*

Placing a Call

The *Ranger Cordless Telephone* selects the last line used. If one line is busy, the phone automatically selects an available line.

To place a call:

Press **TALK** and dial [9] for an outside line.

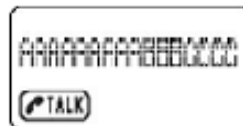

Placing a Call on Hold

- If your system is programmed for Exclusive Hold Preference ... press HOLD once for Exclusive Hold, or twice for System Hold.
- If your system is programmed for System Hold Preference ... press HOLD once for System Hold, or twice for Exclusive Hold (*default setting*).

Retrieving Voice Messages

To enter the Voice Mail system to check for messages:

Press the *preprogrammed* VM GROUP flexible button, OR dial the Voice Mail group number (440-447). You will be prompted to enter your mailbox password.

Transferring a Call

Unscreened

1. Press **TRANS** and dial the desired station number.
2. When the called extension begins to signal, press **TALK** to transfer the call.

Screened

While connected to an outside line:

1. Press **TRANS** and dial the station number. (The called extension signals according to the intercom signal switch position.)
2. When the extension answers, announce transfer.
3. Press **TALK** to complete transfer.

Using the Redial Function

The *Ranger Cordless Telephone* stores the last phone number you dialed.

To redial a number:

Press **TALK + SPEED + [#]**. The phone will redial the last number called.

Programming Functions

Setting Up a Flexible Button

1. Press **TALK + SPEED + SPEED** and press flexible button to be programmed.
2. Dial desired code from the "feature codes" chart, a confirmation tone sounds.
3. When finished, press **TALK** to end programming.

To erase a flexible button, simply program a new flexible button over the existing flexible button. (A system administrator can also set up flexible buttons in the system for all users.)

Default Feature Codes	
All Call Page (Internal & External)	700
Call Back	622
Call Forward (6=All Calls, 7=No Ans, 8=Busy, 9=Busy/No Ans, *=Off-Net)	640+[call fwd code]
Call Park Location - XTS (System)	424-437
Call Park Location - XTSc & STSe (System)	430-437
Call Park Location (Station)	439+[XXX]
Camp On	620
Directory Dial	680
Do Not Disturb	631
Extension Numbers	100-419 (XTS) 100-157 (XTSc & STSe)
External All Call Page* (All External Zones - XTS only)	760
External Page* - Zones 1 or 2 (only Zone 1 XTSc)	76+[1 or 2]
Flash	660
Internal Page* (XTS) - Zones 1-20, All	701-720, 721
Internal Page* (XTSc & STSe) - Zones 1-8, All	701-708, 709
Last Number Redial	[SPEED]+[#]
Message Wait	623
Personal Park	438
Speed Dial Access	[SPEED]+[YYYY]
Save Number Redial	[SPEED]+[*]
VM Group Pilot Numbers	440-447
<i>*Outbound calls only XXX = Station Extension Numbers YYYY = Speed Dial Bin Numbers</i>	

Storing Speed Numbers

1. Press **TALK + SPEED + SPEED**.
2. Dial the speed bin location: 9000 to 9019 = Station Speed numbers, 9020 to 9999 = System Speed numbers (XTSc & STSe = 9020-9099)
3. Dial the desired telephone number and press **SPEED**.
4. Press **TALK** to end speed dial.

Dialing a Speed Number

Press **TALK + SPEED** and dial the speed bin location, OR press the *preprogrammed* speed bin button.

Setting Speed Dial & Last Number Redial Mode

The fixed **SPEED** button on the *Ranger Cordless Telephone* supports a dual function that allows this button to be programmed as either a **SPEED** button or a **LAST NUMBER REDIAL** button.

To convert the **SPEED button to **LAST NUMBER REDIAL**, or **LAST NUMBER REDIAL** back to **SPEED**:**

1. Power OFF the *Ranger Cordless Telephone* and remove the battery from the handset.
2. While pressing the * (star) and # (pound) keys simultaneously, replace the battery in the phone and Power ON the handset.
3. After you hear a confirmation tone:
 - a. Press "Flexible Key 2" to set the Speed dial button function to **SPEED**,
 - or-
 - b. Press "Flexible Key 3" to set the Speed dial button function to **LAST NUMBER REDIAL**.
4. A confirmation tone will sound.

NOTE -- These settings are related to the *Ranger Cordless Telephone* and do not affect the default settings or the user programmed XTS-IP functions assigned to the four Flexible Keys on the *Ranger Cordless Telephone*.



Troubleshooting

If your *Ranger* Cordless Telephone is not performing to your expectations, try these simple steps. If you are still unable to resolve the problems, contact your System Administrator.

NOTE: Do not attempt to service this unit yourself. All service must be done by qualified service personnel.

Problem	Suggestion
Charge light won't illuminate when Handset is placed in Charging Unit.	<ul style="list-style-type: none"> • Make sure the AC Adapter is plugged into the Charging Unit and wall outlet. • Make sure the Handset is properly seated in Charging Unit. • Make sure the Battery Pack is properly placed in the Handset. • Make sure that the charging contacts on the Handset and Charging Unit are clean.
Conversation is interrupted frequently.	<ul style="list-style-type: none"> • Make sure the Base Unit antenna is fully vertical. • Move closer to the Base Unit. • Check for Low Battery warning.
Receive Warning tone and NO SERVICE message.	<ul style="list-style-type: none"> • Move closer to the Base Unit. • Make sure the AC Adapter is plugged into the Base Unit and wall outlet.
Handset doesn't ring.	<ul style="list-style-type: none"> • The Battery Pack may be weak. Charge the Battery Pack for 5-6 hours. • Make sure the Base Unit antenna is fully vertical. • The Handset may be too far away from the Base Unit. • The ringer maybe set to OFF, <i>see page 16</i>. • Make sure the AC Adapter is plugged into the Base Unit and wall outlet.

Specifications

Frequency Control	: Phase Lock Loop
Modulation	: FM
Operating Temperature	: 0° to 50° C (+32° F to +122° F)

Base Unit

Receive/Transmit Frequency	: 902 MHz to 928 MHz
Power Requirements	: 10V DC from supplied AC Adapter
Size	: 4 1/4 in.Wx75/8 in.Dx21/4 in. H
Weight	: Approx. 15.6 oz.

Handset

Receive/Transmit Frequency	: 902 MHz to 928 MHz
Power Requirements	: Ni-MH Battery Pack
Size	: 2 in.Wx11/4 in.Dx51/2 in. H (<i>without antenna</i>)
Weight	: Approx. 5.2 oz. with battery
Battery	: Capacity 750 mAH, 3.6 V
Talk Time	: 4-5 hours (typical)
Standby Time	: 5 days (typical)

(The specifications shown are typical and subject to change without notice.)

Part Numbers

Replacement Parts	Part Number
AC Adapter for Charger	AD970
AC Adapter for Base Unit	EXP9704
Battery - Ni-MH,DC3.6v 750mAh	BT930
Belt Clip	EXP9302
Charger (w/o AC Adapter)	EXP9385
User Guide	3054-00
Wall Mount for Base Unit	EXP9660
Wall Mount for Charger	EXP9360

Optional Accessories	Part Number
Over-the-ear Headset	EXP9530

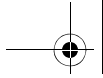

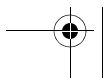
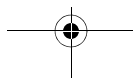
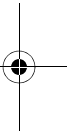
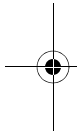

MEMO

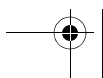
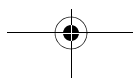
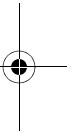
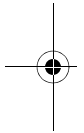
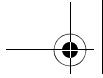

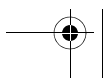
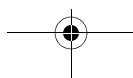
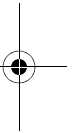
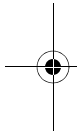
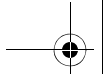

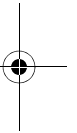
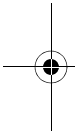
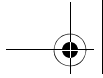



 **VERTICAL** Vertical Communications, Inc.

Published: June 2007

Part Number: 3054-00

